

MANTO[®] G3

The new generation of our 80 kN wall formwork system for large wall areas and big challenges is now more efficient than ever.



At Work For You™



Work Productively

Optional one-sided taper ties increase efficiency.

MANTO Aligning Wedge Clamp allows panels to be quickly and securely connected.

Outer corners made of standard panels – no special panels required.

Less crane time due to ability to move 40 m² formwork elements at once.

Outstanding concreting results with ECOPLY plastic form sheet; easy cleaning and minimal wear.



MANTO® G3

Connecting panels horizontally

Using the MANTO Aligning Panel Clamp

Formwork height: 3.30 m

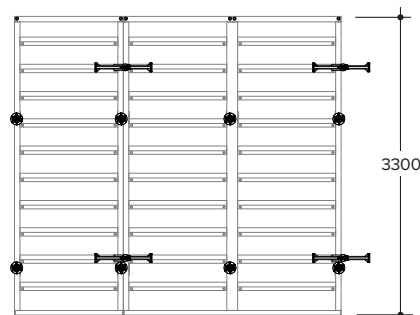

Connecting (extending) panels vertically

Using the MANTO Aligning Panel Clamp, ties and MANTO Panels 2.70 m

Formwork height: 3.90 m

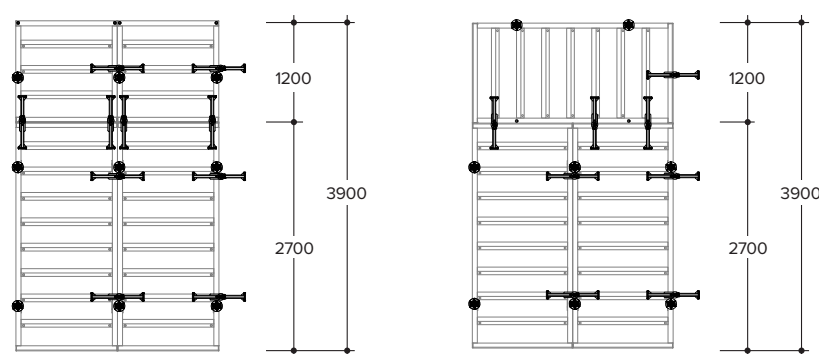

The uppermost tie position on MANTO Panels 330 is needed only when panels are stacked.

Product Benefits

MANTO® G3

Time and cost savings in erection and dismantling thanks to the possibility of single-sided tying

Rapid adaptation to different tie systems thanks to plastic inserts.

Excellent efficiency thanks to tie hole reinforcements built into the frame, which protect the formwork skin and the tie tube from damage.

Selaing cones of the single-sided tie can be used and reused multiple times.

Compatible with the tried and tested MANTO® G2

MANTO[®] G3

Work Safely

Platform can be pre-assembled, with 360° side protection and integrated stairs. Connectors stored on the formwork, where they are easily accessible. Hot-dip galvanised steel frame ensures long serviceable life.



Transport Hook G2: lightweight, powerful, operable from ground level. Transport bolts for safe loading and lateral transports.

TIE PATTERN

MANTO G3 M, stacked

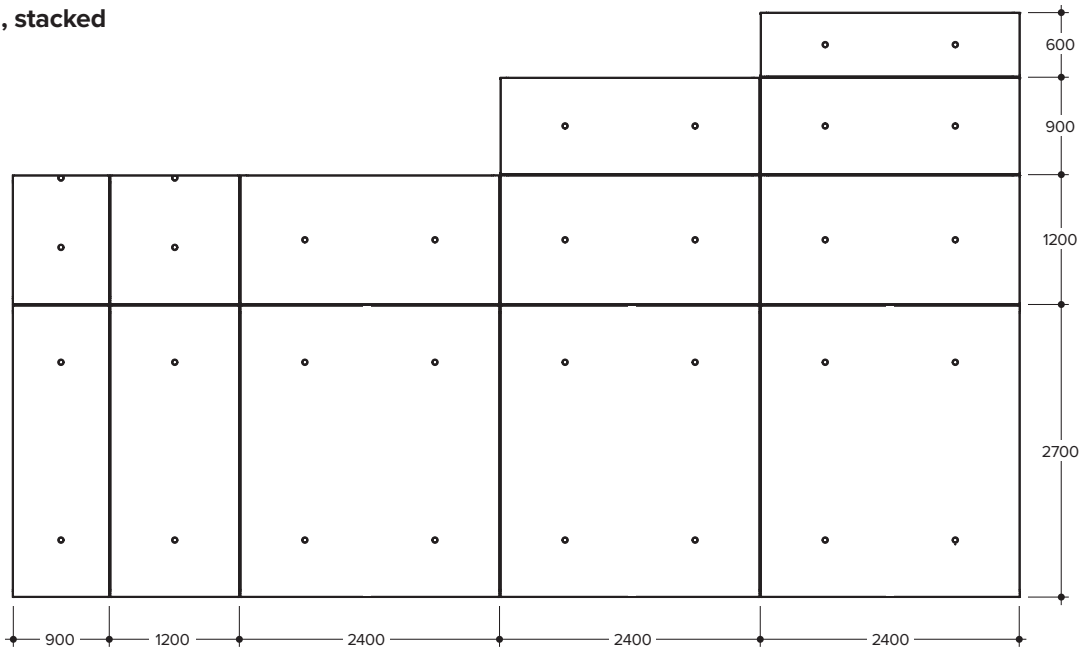

MANTO G3 and MANTO G3 M in the inner corner

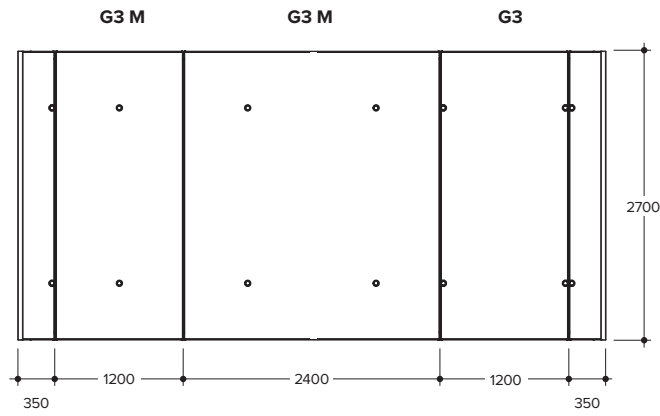

MANTO[®] G3

Technical Data

Product Description	Crane-set large area wall formwork
Panel Widths (cm)	30 45 60 75 90 105 120 240 cm
Panel Heights (cm)	120 270 330 cm
Multi-purpose panels	75 x 120 75 x 270 75 x 330 cm
Profile height	14 cm steel frame profile (closed)
Form lining	ECOPLY full plastic composite sheet (19 mm thick)
Average weight	47 to 75 kg/m ² (including connection elements)
Max. concrete pressure	80 kN/m ² (line 6, some line 7)
Corrosion protection	Fully galvanised steel frame and connection elements
Relevant standards	Complies with EN 1993 DIN 18202 DIN 18218 DIN 18216
Standard connection	Aligning clamp (aligned and flush connection) Aligning wedge clamp
Special connection	Adjustable aligning clamp Corner clamp Universal connector
Inner corners	35/35 cm
Hinged corners	60° to max. 175° angle
Outer corners	Basic panel with outer corner clamps
Forming/stripping times	$t = 0.20 - 0.40 \text{ h/m}^2 *$
Special features	<ul style="list-style-type: none"> Aligning wedge clamp for secure, tight and aligned connection One-sided anchoring possible Plastic formwork lining

► MANTO[®] G3 Integrates with:

- MANTO
- PLATINUM
- Aligning Struts
- RONDA
- Support Frames